



SRI MUTHUKUMARAN INSTITUTE OF TECHNOLOGY

(Approved by AICTE, Accredited by NBA and Affiliated to Anna University, Chennai)

Chikkarayapuram (Near Mangadu), Chennai- 600 069.

DEPARTMENT OF ELECTRONICS AND COMMUNICATION ENGINEERING

YEAR/SEM: IV/VII

SUBJECT CODE & NAME: EC 8751- OPTICAL COMMUNICATION

TWO MARKS QUESTIONS AND ANSWERS

UNIT I – Introduction to OFC

1. What are the limitations of optical fiber communication systems?

- Optical fiber is made up of glass. Because of the impurities present with the fiber It results in absorption, which leads to loss of light in the optical fiber.
- It is costly.
- Maximum limitation of the bandwidth of the signals can be carried by the fiber due to spreading of pulse.

2. What is the necessity of cladding for an optical fiber?

The necessity of cladding for an optical fiber is

- To avoid leakage of light from the fiber
- To avoid mechanical strength for the fiber
- To protect core from scratches and other mechanical damages.

3. List the advantages of mono-mode fiber.

The advantages of mono-mode fiber are

- No internal dispersion
- Information capacity of single mode fiber is large.

4. Define - Acceptance Angle

The maximum angle Φ_{\max} with which a ray of light can enter through the entrance end of the fibre and still be totally internally reflected is called acceptance angle of the fiber.

5. List the uses of optical fiber.

The uses of optical fibers are as follows

- To act as light source at the inaccessible places
- To transmit the optical images. (example: endoscopy) To act as sensors to do mechanical, electrical and magnetic measurements
- To transmit the information which are in the form of coded signals of the telephone communications, computer data etc.

6. List the disadvantages of mono-mode fiber.

The disadvantages of mono-mode fiber are

- Launching of light into single mode and joining of two fibers are very difficult.
- Fabrication is very difficult and so that fiber is so costly.

7. What is the principle used in the working of fibers as light guides?

The phenomenon of total internal reflection is used to guide the light in the optical fiber. To get total reflection, the ray should travel from denser region rarer region i.e. from core to clad region. Of the fiber and the angle of incidence in the denser medium should be greater than the critical angle of that medium.

8. Define- Refraction

When light travels from air medium to glass medium, bending of light may occur. This is called refraction.

9. What is critical angle?

When we increase the incident angle with respect to normal, at some incident angle, the dielectric of surface and ϕ_2 becomes 90 and such incident angle is called critical angle.

10. What is Snell's law?

The relationship at the interface is called Snell's Law. It is given by the equation

$$n_1 \sin \phi_1 = n_2 \sin \phi_2$$

11. What is meant by mode coupling?

The effect of coupling energy from one mode to another mode is known as mode coupling. The cause of mode coupling is due to waveguide perturbations such as deviations Of the fiber axis from straightness variations in the core diameter, irregularities at the Core- cladding interface and refractive index variations.

12. What is V number of a fiber?

Normalized frequency or V number is a dimensionless parameter and represent the relationship among three design parameters variables of the fiber viz core radius a, relative refractive index Δ and the operating wavelength λ .

It is expressed as $V = (2 * \pi * \text{Numerical aperture}(a)) / \lambda$

13. Compare Ray optics and wave optics.

Ray optics	Wave optics
It is used to represent the light propagation	It is used to analyze mode theory
It is used to study reflection and refraction of light	It is used to analyze diffraction and interference of light waves

14. Differentiate between mono-mode fiber and multi-mode fiber.

Mono-mode fiber	Multi-mode fiber
Only one ray passes through the fiber	More than one ray passes through fiber at a time.
Coupling efficiency is less.	Coupling efficiency is large.
LED is not suitable for single mode fiber.	LED is suitable for multi-mode fiber
Intermodal dispersion is not present.	Intermodal dispersion is present
Fabricating single mode fiber is difficult.	Fabricating multi-mode fiber is easy.

15. What is meant by linearly polarized mode?

The field components HE, EH, TE, TM forms linearly polarized modes. Linearly polarized Modes are labeled LP_{jm} where j and m are integers designation mode solutions.

16. What are the three windows of optical communications?

The three wavelengths 850nm, 1300nm, and 1500nm are three optical windows of optical communication system. Since only at this wavelength silica fiber loss is minimum.

17. Define – Fiber Optic system

Fiber optic system is nothing but a fiber-optic cable is essentially light pipe that is used to carry a light beam from one place to another.

18. What are the advantages of graded index fiber?

The advantages of graded index fiber are

- It provides higher bandwidth.
- It exhibits less intermodal dispersion because the different group velocities of the mode tend to be normalized by the index grading.

19. What is step index fiber?

Step index fiber is a cylindrical waveguide that has the central core with uniform refractive index n_1 surrounded by outer cladding with refractive index of n_2 . The refractive index of the core is constant and is larger than the refractive index of the cladding. It makes a step change at the core cladding interface.

20. Why step index single mode fiber preferred for long distance communication?

The step index single mode fiber is preferred for long distance communication because

- They exhibit higher transmission bandwidth because of low fiber losses.
- They have superior transmission quality because of the absence of the modal noise.
- The installation of single mode fiber is easy and will not require any fiber replacement over twenty plus years.

21. Define- Birefringence

Manufactured optical fibers have imperfections such as asymmetrical lateral stresses, non - circular cores and variations in refractive index profiles. These imperfections break the circular symmetry of the ideal fiber and lift the degeneracy of the two modes. These modes propagate with different phase velocity and it is called as fiber birefringence.

22. What types of fibers are used commonly?

Based on refractive index profile- step index fiber, graded index fiber. Based on propagation – Mono mode or single mode fiber, multi -mode fiber.

23. Define – Wavefront

For plane waves, some constant phase points from a surface which is referred to as wavefront.

24. What is an index profile?

The index profile of an optical fiber is a graphical representation of the magnitude of the refractive index across the fiber.

25. What are leaky modes in optical fibers?

In leaky modes, the fields are confined partially in the fiber core and attenuated as they propagate along the fiber length, due to radiation and tunnel effect.

26. What is the purpose of cladding?

Cladding provides mechanical strength, reduces scattering loss resulting from dielectric discontinuities at the core surface and protects the core from absorbing surface contaminants with which it could come into contact.

27. What are leaky rays?

The leaky rays are only partially confined to the core of the circular optical fiber and attenuate as the light travels along the optical waveguide.

28. What are the conditions for total internal reflection?

The conditions for total internal reflections are:

- The ray should travel from denser to rarer medium. i.e. from core to clad region of the optical fiber.
- The angle of incidence in the denser should greater than the critical angle of that medium.

29. What are guided modes?

Guided modes are a pattern of electric and magnetic field distributions that is repeated along the fiber at equal intervals.

30. Define- Mode

Mode is the pattern of distribution of electric and magnetic fields.

Transverse- Electric mode (TE) Transverse

Magnetic mode (TM)

31. Define - Mode-Field Diameter

The fundamental parameter of a single mode fibre is said to be the mode field diameter. It is possible to determine the mode-field diameter with the help of the fundamental LP₀₁ mode.

32. What are meridional rays?

Meridional rays are the rays which follows zig -zag path when they travel through fiber and for every reflection it will cross the fiber axis.

33. When do you have phase shift during total internal reflection of light?

When the light ray travels from denser medium to rarer medium, if the angle of incidence is greater than the critical angle of Core medium, then there is a phase shift for both TE and TM waves.

34. State Goes- Haenchen effect.

Goes- Haenchen effect states that, there is a lateral shift of the reflected ray at the point of incidence and at the core-cladding interface. This lateral shift is called the **Goes-Haenchen** effect.

35. Differentiate between meridional rays and skew rays.

A **meridional ray** is a ray that passes through the axis of an optical fiber.

A **skew ray** is a ray that travels in a non-planar zig-zag path and never crosses the axis of an optical fiber.

36. What do you mean by RAY?

In optics a **ray** is an idealized model of light, obtained by choosing a line that is perpendicular to the wavefronts of the actual light, and that points

in the direction of energy flow. Rays are used to model the propagation of light through an optical system, by dividing the real light field up into discrete rays that can be computationally propagated through the system by the techniques of ray tracing.

37. What are skew rays?

A **skew ray** is a ray that travels in a non-planar zig-zag path and never crosses the axis of an optical fiber.

38. What are the advantages of optical network?

The advantages of optical network are as follows:

- Low signal attenuation (as low as 0.2 dB/km),
- Immunity to electromagnetic interference
- High security of signal because of no electromagnetic radiation,
- Huge bandwidth
- Low signal distortion, suitable for carrying digital information,
- Low power requirement
- No crosstalk and interferences between fibers in the same cable,
- Low material usage, small space requirement, light weight, non- flammable, cost-effective and high electrical resistance

39. What is an optical network?

An optical network is not necessarily all-optical: the transmission is certainly optical, but the switching could be optical, or electrical, or hybrid Also, an optical is not necessarily packet-switched.

40. What are the advantages of optical communication?

The advantages of optical communication are

- Low transmission losses
- Electrical isolation
- Small size and weight
- No electromagnetic interference

41. Define – Longitudinal modes

Longitudinal modes are associated with the length of the cavity and determine the typical spectrum of the emitted radiation.

42. Define – Transverse Modes

Transverse modes are associated with the electromagnetic field and beam profile in the direction perpendicular to the plane of PN junction. They determine the Laser characteristics as the radiation pattern and the threshold current density.

1. Explain the elements of optical fiber transmission link with a neat diagram and briefly outline the evolution of fiber optic system.

An optical fiber communication system is similar in basic concept to any type of communication system.

A block schematic of a general communication system is shown in Fig. the function of which is to convey the signal from the information source over the transmission medium to the destination.

The communication system therefore consists of a transmitter or modulator linked to the information source, the transmission medium, and a receiver or demodulator at the destination point.

In electrical communications the information source provides an electrical signal, usually derived from a message signal which is not electrical (e.g. sound), to a transmitter comprising electrical and electronic components which converts the signal into a suitable form for propagation over the transmission medium.

This is often achieved by modulating a carrier, which, as mentioned previously, may be an electromagnetic wave.

For optical fiber communications the system shown in Fig. may be considered in slightly greater detail, as given in Fig. In this case the information source provides an electrical signal to a transmitter comprising an electrical stage which drives an optical source to give modulation of the light wave carrier.

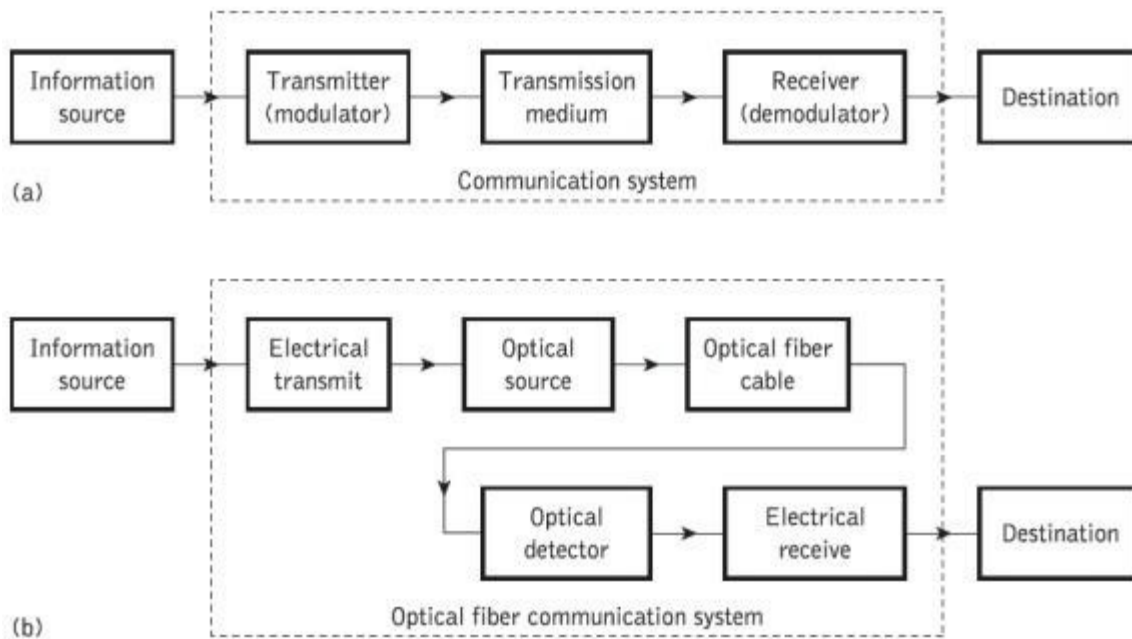

Figure 1.1 (a) The general communication system. (b) The optical fiber communication system

The optical source which provides the electrical–optical conversion may be either a semiconductor laser or light-emitting diode (LED).

The transmission medium consists of an optical fiber cable and the receiver consists of an optical detector which drives a further electrical stage and hence provides demodulation of the optical carrier.

Photodiodes (p–n, p–i–n or avalanche) and, in some instances, phototransistors and photoconductors are utilized for the detection of the optical signal and the optical–electrical conversion.

Thus there is a requirement for electrical interfacing at either end of the optical link and at present the signal processing is usually performed electrically.

2. Draw and briefly explain step and graded index fibers.

Step index fibers

The optical fiber considered in the preceding sections with a core of constant refractive index n_1 and a cladding of a slightly lower refractive index n_2 is known as step index fiber.

This is because the refractive index profile for this type of fiber makes a step change at the core–cladding interface, as indicated in Fig., which illustrates the two major types of step index fiber.

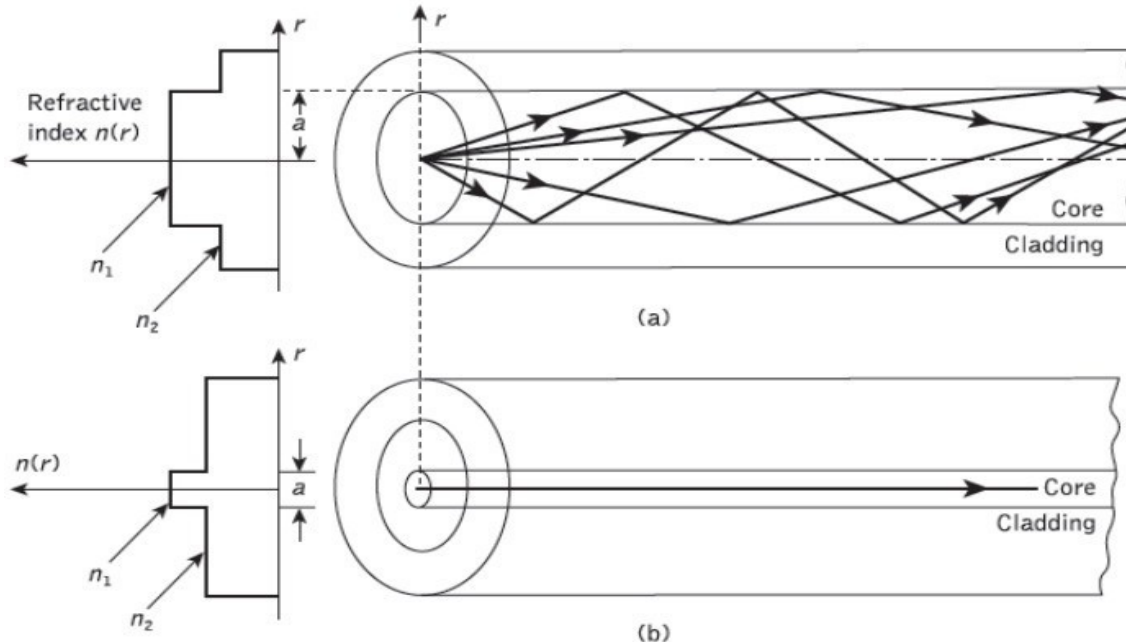

Figure 1.14 The refractive index profile and ray transmission in step index fibers: (a) multimode step index fiber; (b) single-mode step index fiber

The refractive index profile may be defined as:

$$n(r) = \begin{cases} n_1 & r < a & \text{(core)} \\ n_2 & r \geq a & \text{(cladding)} \end{cases}$$

in both cases.

Fig. shows a multimode step index fiber with a core diameter of around 50 μm or greater, which is large enough to allow the propagation of many modes within the fiber core. This is illustrated in Fig. by the many different possible ray paths through the fiber.

Fig. shows a single-mode or monomode step index fiber which allows the propagation of only one transverse electromagnetic mode (typically HE₁₁), and hence the core diameter must be of the order of 2 to 10 μm .

The propagation of a single mode is illustrated in Fig. as corresponding to a single ray path only (usually shown as the axial ray) through the fiber.

The single-mode step index fiber has the distinct advantage of low intermodal dispersion (broadening of transmitted light pulses), as only one mode is transmitted, whereas with multimode step index fiber considerable dispersion may occur due to the differing group velocities of the propagating modes.

- a) The use of spatially incoherent optical sources (e.g. most light-emitting diodes) which cannot be efficiently coupled to single-mode fibers.
- b) Larger numerical apertures, as well as core diameters, facilitating easier coupling to optical sources
- c) Lower tolerance requirements on fiber connectors

Multimode step index fibers allow the propagation of a finite number of guided modes along the channel.

The number of guided modes is dependent upon the physical parameters (i.e. relative refractive index difference, core radius) of the fiber and the wavelengths of the transmitted light which are included in the normalized frequency V for the fiber.

Mode propagation does not entirely cease below cutoff. Modes may propagate as unguided or leaky modes which can travel considerable distances along the fiber. Nevertheless, it is the guided modes

$$M_s \approx \frac{V^2}{2} \tag{1.49}$$

which are of paramount importance in optical fiber communications as these are confined to the fiber over its full length.

The total number of guided modes or mode volume M_s for a step index fiber is related to the V value for the fiber by the approximate expression Which allows an estimate of the number of guided modes

propagating in a particular multimode step index fiber.

Graded index fibers

Graded index fibers do not have a constant refractive index in the core* but a decreasing core index $n(r)$ with radial distance from a maximum value of n_1 at the axis to a constant value n_2 beyond the core radius a in the cladding. This index variation may be represented as:

$$n(r) = \begin{cases} n_1(1 - 2\Delta(r/a)^\alpha)^{\frac{1}{2}} & r < a \quad (\text{core}) \\ n_1(1 - 2\Delta)^{\frac{1}{2}} = n_2 & r \geq a \quad (\text{cladding}) \end{cases} \quad (1.50)$$

where Δ is the relative refractive index difference and α is the profile parameter which gives the characteristic refractive index profile of the fiber core. Equation (1.50) which is a convenient method of expressing the refractive index profile of the fiber core as a variation of α , allows representation of

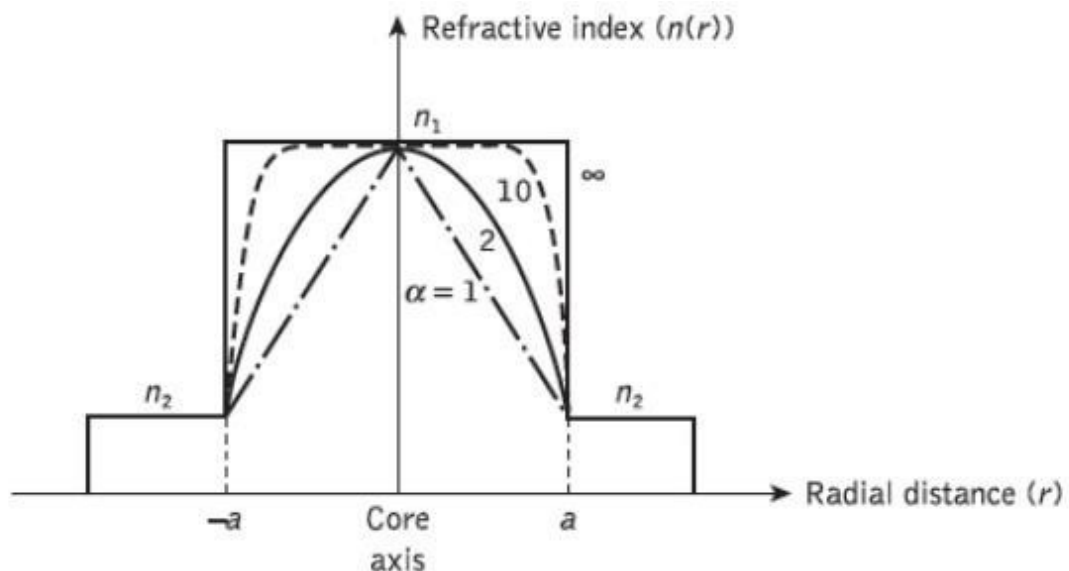

Figure 1.15 Possible fiber refractive index profiles for different values of α (given in Eq. (1.50)) the step index profile when $\alpha = \infty$, a parabolic profile when $\alpha = 2$ and a triangular profile when $\alpha = 1$. This range of refractive index profiles is illustrated in Figure 1.15

The graded index profiles which at present produce the best results for multimode optical propagation have a near parabolic refractive index profile core

with $\alpha \sim 2$. Fibers with such core index profiles are well established and consequently

when the term 'graded index' is used without qualification it usually refers to a fiber with this profile.

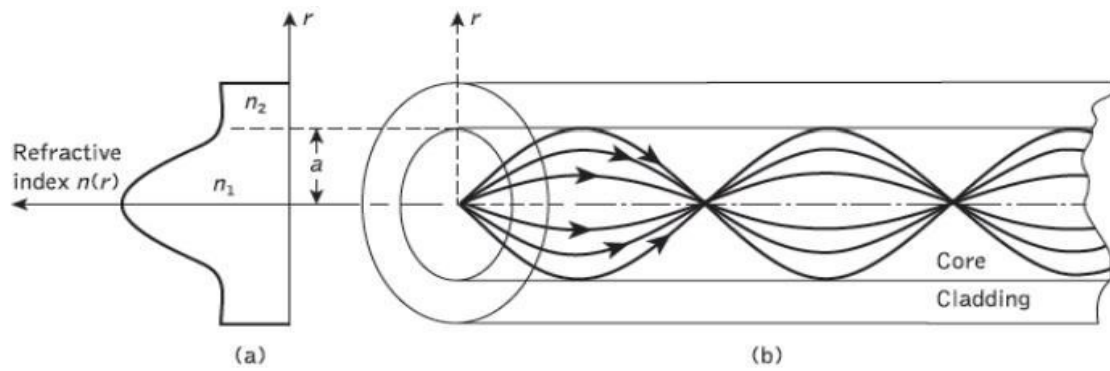

Figure 1.16 The refractive index profile and ray transmission in a multimode graded index fiber

For this reason in this section we consider the waveguiding properties of graded index fiber with a parabolic refractive index profile core.

A multimode graded index fiber with a parabolic index profile core is illustrated in Figure 1.16. It may be observed that the meridional rays shown appear to follow curved paths through the fiber core.

Using the concepts of geometric optics, the gradual decrease in refractive index from the center of the core creates many refractions of the rays as they are effectively incident on a large number or high to low index interfaces.

This mechanism is illustrated in Fig. where a ray is shown to be gradually curved, with an ever-increasing angle of incidence, until the conditions for total internal reflection are met, and the ray travels back towards the core axis, again being continuously refracted.

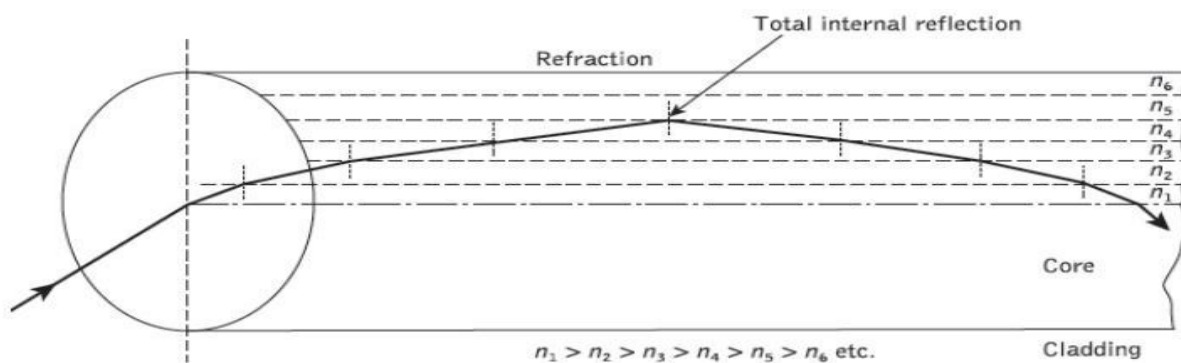

Figure 1.17 An expanded ray diagram showing refraction at the various high to low index interfaces within a graded index fiber, giving an overall curved ray path into the outer regions of the core.

Multimode graded index fibers exhibit far less intermodal dispersion than multimode step index fibers due to their refractive index profile.

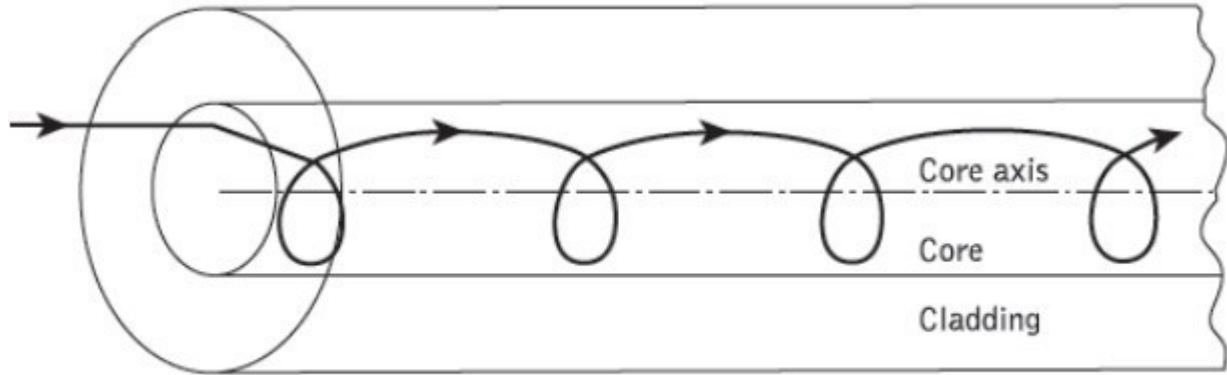

Figure 1.18 A helical skew ray path within a graded index fiber

However, the near axial rays are transmitted through a region of higher refractive index and therefore travel with a lower velocity than the more extreme rays. This compensates for the shorter path lengths and reduces dispersion in the fiber.

3. Define group delay. Mention its significance with expressions.

The transit time or group delay τ_g for a light pulse propagating along a unit length of fiber is the inverse of the group velocity v_g . Hence:

$$\tau_g = \frac{1}{v_g} = \frac{d\beta}{d\omega} = \frac{1}{c} \frac{d\beta}{dk} \quad (1.61)$$

The group index of a uniform plane wave propagating in a homogeneous medium has been determined as:

$$N_g = \frac{c}{v_g}$$

However, for a single-mode fiber, it is usual to define an effective group index* N_{ge} By:

$$N_{ge} = \frac{c}{v_g} \quad (1.62)$$

Where v_g is considered to be the group velocity of the fundamental fiber mode. Hence, the specific group delay of the fundamental fiber mode becomes:

$$\tau_g = \frac{N_{ge}}{c} \quad (1.63)$$

Moreover, the effective group index may be written in terms of the effective refractive index n_{eff} defined in Eq. (1.56) as:

$$N_{ge} = n_{\text{eff}} - \lambda \frac{dn_{\text{eff}}}{d\lambda} \quad (1.64)$$

$$\beta = k[(n_1^2 - n_2^2)b + n_2^2] \approx kn_2[1 + b\Delta] \quad (1.65)$$

Furthermore, approximating the relative refractive index difference as $(n_1 - n_2)/n_2$, for a weakly guiding fiber where $\Delta \ll 1$, we can use the approximation :

Where N_{g1} and N_{g2} are the group indices for the fiber core and cladding regions respectively. Substituting Eq. (1.65) for β into Eq. (1.67) and using the approximate expression given in Eq. (1.66), we obtain the group delay per unit distance as:

$$\tau_g = \frac{1}{c} \left[N_{g2} + (N_{g1} - N_{g2}) \frac{d(Vb)}{dV} \right] \quad (1.67)$$

The dispersive properties of the fiber core and the cladding are often about the same and therefore the wavelength dependence of can be ignored. Hence the group delay can be written as:

$$\tau_g = \frac{1}{c} \left[N_{g2} + n_2 \Delta \frac{d(Vb)}{dV} \right] \quad (1.68)$$

The initial term in Eq. (1.68) gives the dependence of the group delay on wavelength caused when a uniform plane wave is propagating in an infinitely extended medium with a refractive index which is equivalent to that of the fiber cladding. However, the second term results from the waveguiding properties of the fiber only and is determined by the mode delay factor $d(Vb)/dV$, which describes the change in group delay caused by the changes in power distribution between the fiber core and cladding. The mode delay factor is a further universal parameter which plays a major part in the theory of single-mode fibers. Its variation with normalized frequency for the fundamental mode in a step index fiber is shown in Figure .

The Gaussian approximation

The field shape of the fundamental guided mode within a single-mode step index fiber for two values of normalized frequency is displayed in Figure.

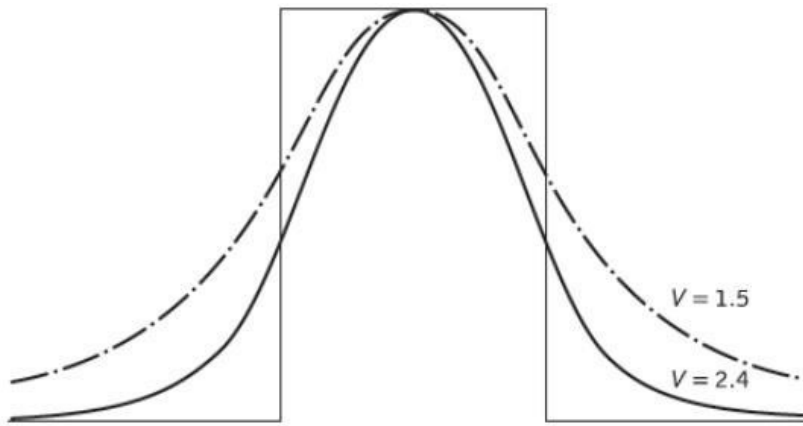

Figure 1.22 Field shape of the fundamental mode for normalized frequencies, $V=1.5$ and $V=2.4$

As may be expected, considering the discussion in Section 2.4.1, it has the form of a Bessel function ($J_0(r)$) in the core region matched to a modified Bessel function ($K_0(r)$) in the cladding. Depending on the value of the normalized frequency, a significant proportion of the modal power is propagated in the cladding region, as mentioned earlier. Hence, even at the cutoff value (i.e. V_c) only about 80% of the power propagates within the fiber core.

It may be observed from Figure 1.22 that the shape of the fundamental LP01 mode is similar to a Gaussian shape, which allows an approximation of the exact field distribution by a Gaussian function.* The approximation may be investigated by writing the scalar wave equation in the form:

$$\nabla^2 \psi + n^2 k^2 \psi = 0 \quad (1.69)$$

where k is the propagation vector defined in Eq. (1.33) and $n(x, y)$ is the refractive index of the fiber, which does not generally depend on z , the coordinate along the fiber axis. It should be noted that the time dependence $\exp(j\omega t)$ has been omitted from the scalar wave equation to give the reduced wave equation† in Eq. (1.69). This representation is valid since the guided modes of a fiber with a small refractive index difference have one predominant transverse field component, for example E_y . By contrast E_x and the longitudinal component are very much smaller.

The field of the fundamental guided mode may therefore be considered as a scalar quantity and need not be described by the full set of Maxwell's equations. Hence Eq. (1.69) may be written as:

$$\nabla^2 \phi + n^2 k^2 \phi = 0 \quad (1.70)$$

where ϕ represents the dominant transverse electric field component.

The near-Gaussian shape of the predominant transverse field component of the fundamental mode has been demonstrated for fibers with a wide range of refractive index distributions. This proves to be the case not only for the LP01 mode of the step index fiber, but also for the modes with fibers displaying arbitrary graded refractive index distributions.

4 . Explain the wave equations for a cylindrical fiber in detail.

Cylindrical fiber

The exact solution of Maxwell's equations for a cylindrical homogeneous core dielectric waveguide* involves much algebra and yields a complex result. Although the presentation of this mathematics is beyond the scope of this text, it is useful to consider the resulting modal fields. In common with the planar guide (Section 1.3.2), TE (where $E_z = 0$) and TM (where $H_z = 0$) modes are obtained within the dielectric cylinder. The cylindrical waveguide, however, is bounded in two dimensions rather than one. Thus two integers, l and m , are necessary in order to specify the modes, in contrast to the single integer (m) required for the planar guide.

For the cylindrical waveguide we therefore refer to TE_{lm} and TM_{lm} modes. These modes correspond to meridional rays (see Section 1.2.1) traveling within the fiber. However, hybrid modes where E_z and H_z are nonzero also occur within the cylindrical waveguide. These modes, which result from skew ray propagation (see Section 1.2.4) within the fiber, are designated HE_{lm} and EH_{lm} depending upon whether the components of \mathbf{H} or \mathbf{E} make the larger contribution to the transverse (to the fiber axis) field. Thus an exact description of the modal fields in a step index fiber proves somewhat complicated.

Fortunately, the analysis may be simplified when considering optical fibers for communication purposes. These fibers satisfy the weakly guiding approximation where the relative index difference $\Delta 1$. This corresponds to small grazing angles θ in Eq. (1.34). In fact is usually less than 0.03 (3%) for optical communications fibers. For weakly guiding structures with dominant forward propagation, mode theory gives dominant transverse field components. Hence approximate solutions for the full set of HE, EH, TE and TM modes may be given by two linearly polarized components.

These linearly polarized (LP) modes are not exact modes of the fiber except for the fundamental (lowest order) mode. However, as in weakly guiding fibers is very small, then HE–EH mode pairs occur which have almost identical propagation constants. Such modes are said to be degenerate. The superpositions of these degenerating modes characterized by a common propagation constant correspond to particular LP modes regardless of their HE, EH, TE or TM field configurations. This linear combination of degenerate modes obtained from the exact solution produces a useful simplification in the analysis of weakly guiding fibers.

The relationship between the traditional HE, EH, TE and TM mode designations and the LP_{lm} mode designations is shown in Table 1.1. The mode subscripts l and m are related to the electric field intensity profile for a particular LP mode (see Figure 1.11(d)). There are in general $2l$ field maxima around the circumference of the fiber core and m field

maxima along a radius vector. Furthermore, it may be observed from Table that the notation for labeling the HE and EH modes has changed from that specified for the exact solution in the cylindrical waveguide mentioned previously.

Table 1.1 Correspondence between the lower order in linearly polarized modes and the traditional exact modes from which they are formed

<i>Linearly polarized</i>	<i>Exact</i>
LP_{01}	HE_{11}
LP_{11}	$HE_{21}, TE_{01}, TM_{01}$
LP_{21}	HE_{31}, EH_{11}
LP_{02}	HE_{12}
LP_{31}	HE_{41}, EH_{21}
LP_{12}	$HE_{22}, TE_{02}, TM_{02}$
LP_{lm}	$HE_{2m}, TE_{0m}, TM_{0m}$
$LP_{lm} (l \neq 0 \text{ or } 1)$	$HE_{l-1,m}, EH_{l-1,m}$

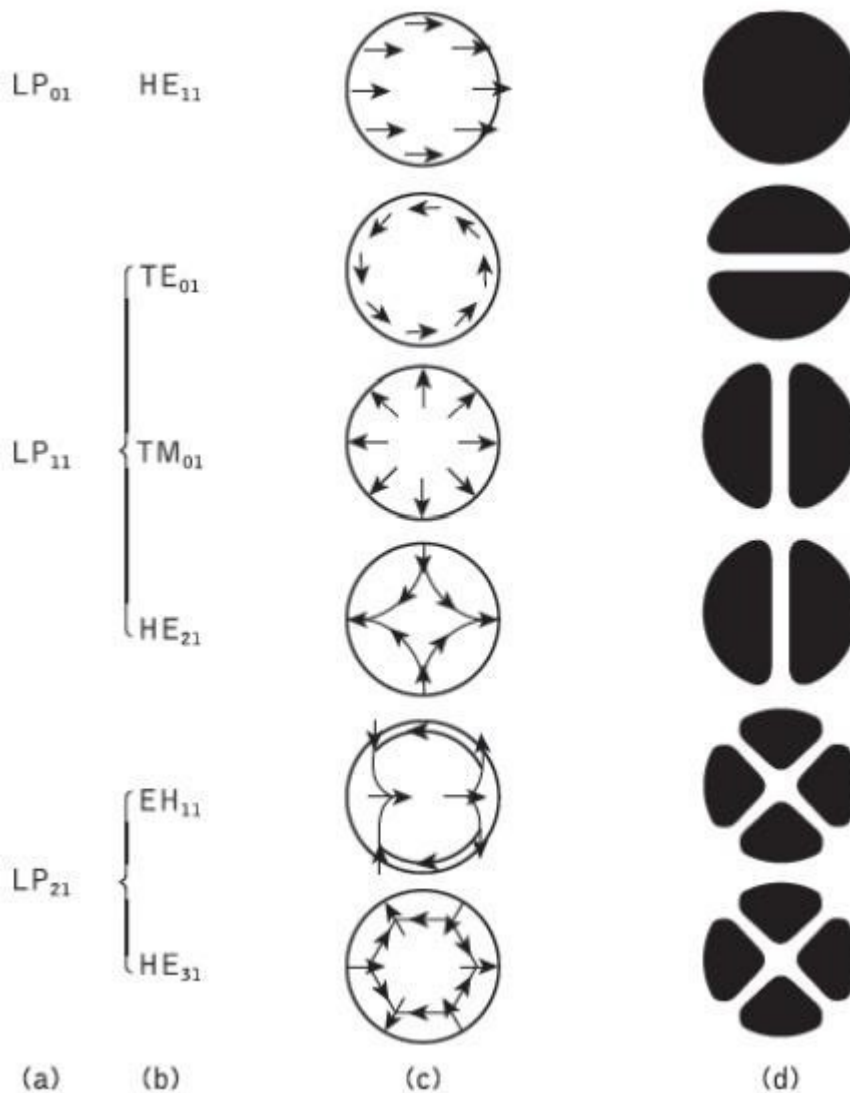

Figure 1.11 The electric field configurations for the three lowest LP modes illustrated in terms of their constituent exact modes: (a) LP mode designations; (b) exact mode designations; (c) electric field distribution of the exact modes; (d) intensity distribution of E_x for the exact modes indicating the electric field intensity profile for the corresponding LP modes

The subscript l in the LP notation now corresponds to HE and EH modes with labels $l + 1$ and $l - 1$ respectively. The electric field intensity profiles for the lowest three LP modes, together with the electric field distribution of their constituent exact modes, are shown in Figure .

5. Explain the phenomenon of total internal reflection using Snell’s law with figures and calculations.

Total internal reflection

To consider the propagation of light within an optical fiber utilizing the ray theory model it is necessary to take account of the refractive index of the dielectric medium. The refractive index of a medium is defined as the ratio of the velocity of light in a vacuum to the velocity of light in the medium.

A ray of light travels more slowly in an optically dense medium than in one that is less dense, and the refractive index gives a measure of this effect. When a ray is incident on the interface between two dielectrics of differing refractive indices (e.g. glass–air), refraction occurs, as illustrated in Figure 1.2(a). It may be observed that the ray approaching the interface is propagating in a dielectric of refractive index n and is at an angle ϕ to the normal at the surface of the interface. If the dielectric on the other side of the interface has a refractive index n which is less than n_1 , then the refraction is such that the ray path in this lower index medium is at an angle to the normal, where is greater than . The angles of incidence and refraction are related to each other and to the refractive indices of the dielectrics by Snell’s law of refraction, which states that:

$$n_1 \sin \phi_1 = n_2 \sin \phi_2$$

Or

$$\frac{\sin \phi_1}{\sin \phi_2} = \frac{n_2}{n_1} \tag{1.1}$$

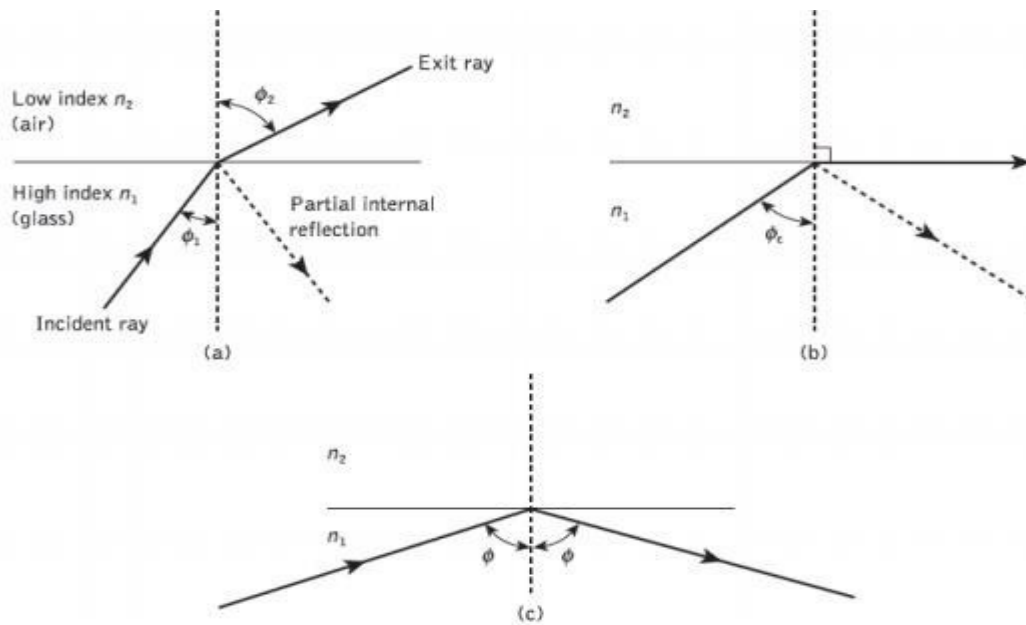

Figure 1.2 Light rays incident on a high to low refractive index interface (e.g. glass air): (a) refraction; (b) the limiting case of refraction showing the critical ray at an angle ϕ_c (c) total internal reflection where $\phi > \phi_c$

It may also be observed in Figure 1.2(a) that a small amount of light is reflected back into the originating dielectric medium (partial internal reflection). As n_1 is greater than n_2 , the angle of refraction is always greater than the angle of incidence. Thus when the angle of refraction is 90° and the refracted ray emerges parallel to the interface between the dielectrics, the angle of incidence must be less than 90° . This is the limiting case of refraction and the angle of incidence is now known as the critical angle ϕ_c , as shown in Figure 1.2(b). From Eq. (1.1) the value of the critical angle is given by

$$\sin \phi_c = \frac{n_2}{n_1} \quad (1.2)$$

At angles of incidence greater than the critical angle the light is reflected back into the originating dielectric medium (total internal reflection) with high efficiency (around 99.9%). Hence, it may be observed in Figure 1.2(c) that total internal reflection occurs at the interface between two dielectrics of differing refractive indices when light is incident on the dielectric of lower index from the dielectric of higher index, and the

angle of incidence of the ray exceeds the critical value. This is the mechanism by which light at a sufficiently shallow angle (less than 90° – may be considered to propagate down an optical fiber with low loss.

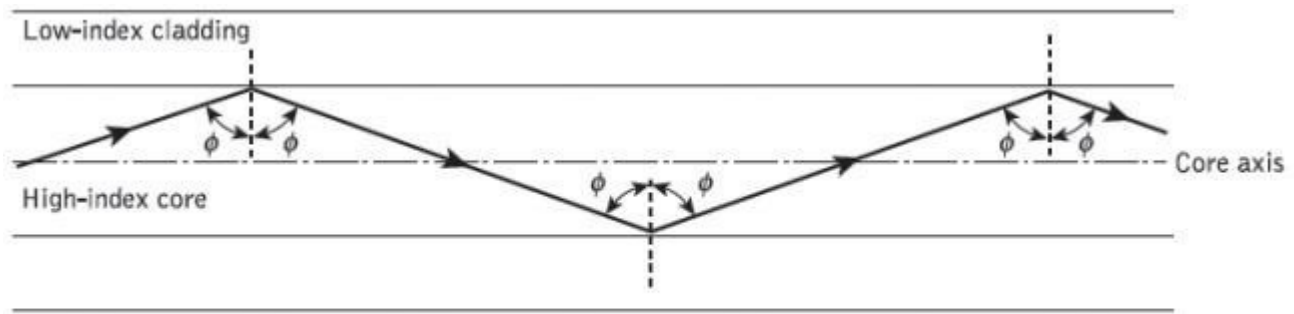

Figure 1.3 The transmission of a light ray in a perfect optical fiber

Figure 1.3 illustrates the transmission of a light ray in an optical fiber via a series of total internal reflections at the interface of the silica core and the slightly lower refractive index silica cladding. The ray has an angle of incidence ϕ at the interface which is greater than the critical angle and is reflected at the same angle to the normal.

The light ray shown in Fig. is known as a meridional ray as it passes through the axis of the fiber core. This type of ray is the simplest to describe and is generally used when illustrating the fundamental transmission properties of optical fibers. It must also be noted that the light transmission illustrated in Figure 1.3 assumes a perfect fiber, and that any discontinuities or imperfections at the core–cladding interface would probably result in refraction rather than total internal reflection, with the subsequent loss of the light ray into the cladding.

It may be observed from the field configurations of the exact modes that the field strength in the transverse direction (E_x or E_y) is identical for the modes which belong to the same LP mode.

Hence the origin of the term ‘linearly polarized’.

Using Eq. (1.31) for the cylindrical homogeneous core waveguide under the weak guidance conditions outlined above, the scalar wave equation can be written in the form

$$\frac{d^2\psi}{dr^2} + \frac{1}{r} \frac{d\psi}{dr} + \frac{1}{r^2} \frac{d^2\psi}{d\phi^2} + (n_1^2 k^2 - \beta^2) \psi = 0 \quad (1.41)$$

where ψ is the field (\mathbf{E} or \mathbf{H}), n_1 is the refractive index of the fiber core, k is the propagation constant for light in a vacuum, and r and ϕ are cylindrical coordinates. The propagation constants of the guided modes β lie in the range:

$$n_2 k < \beta < n_1 k \quad (1.42)$$

where n_2 is the refractive index of the fiber cladding. Solutions of the wave equation for the cylindrical

fiber are separable, having the form:

$$\psi = E(r) \left[\begin{array}{l} \cos l\phi \\ \sin l\phi \end{array} \exp(\omega t - \beta z) \right] \quad (1.43)$$

where in this case ψ represents the dominant transverse electric field component. The periodic dependence on ϕ following $\cos l\phi$ or $\sin l\phi$ gives a mode of radial order l . Hence the fiber supports a finite number of guided modes of the form of Eq. (1.43).

Introducing the solutions given by Eq. (1.43) into Eq. (1.41) results in a differential equation of the form:

$$\frac{d^2 E}{dr^2} + \frac{1}{r} \frac{dE}{dr} + \left[(n_1 k^2 - \beta^2) - \frac{l^2}{r^2} \right] E = 0 \quad (1.45)$$

For a step index fiber with a constant refractive index core, Eq. (1.43) is a Bessel differential equation and the solutions are cylinder functions. In the core region the solutions are Bessel functions denoted by J_l .

A graph of these gradually damped oscillatory functions (with respect to r) is shown in Figure 1.12(a). It may be noted that the field is finite at $r = 0$ and may be represented by the zero-order Bessel function J_0 . However, the field vanishes as r goes to infinity and the solutions in the cladding are therefore modified Bessel functions denoted by K_l .

These modified functions decay exponentially with respect to r , as illustrated in Figure 1.12(b). The electric field may therefore be given by:

$$\begin{aligned} \mathbf{E}(r) &= G J_l(UR) && \text{for } R < 1 \text{ (core)} \\ &= G J_l(U) \frac{K_l(WR)}{K_l(W)} && \text{for } R > 1 \text{ (cladding)} \end{aligned} \quad (1.45)$$

Where G is the amplitude coefficient and $R = r/a$ is the normalized radial coordinate when a is the radius of the fiber core; U and W , which are the eigenvalues in the core and cladding respectively,* are defined as:

$$U = a(n_1^2 k^2 - \beta^2)^{\frac{1}{2}} \quad (1.46)$$

$$W = a(\beta^2 - n_2^2 k^2)^{\frac{1}{2}} \quad (1.47)$$

